

MARCY CARDIO TRAMPOLINE TRAINER ASG-40

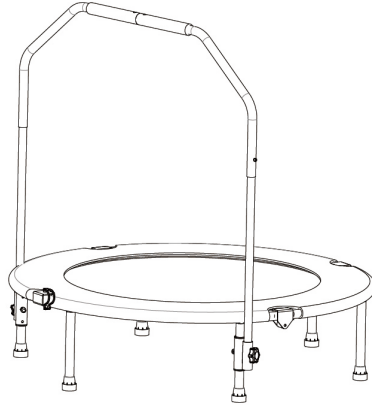

WARNING

1. **Read the warning notice and instruction prior assembling and using the equipment.**
2. This equipment is not intended to use by children under 12 years of age.
3. Do not leave children unattended with the equipment.
4. This equipment is intended to use indoor.
5. Position the equipment on a clear, leveled surface. Make sure the surfaces are free of objects that may cause tipping over. Keep objects away, which could interfere with the performer.
6. Inspect before use. Keep frame padding in place. Never use the equipment if it is not functioning properly.
7. Always wear appropriate workout clothing when exercising.
8. Do not use the equipment when it is wet.
9. Learn fundamental bounces and body position thoroughly. For skill training, contact a certified trainer.
10. Do not attempt or allow somersaults. Landing on the head or neck can cause serious injury, paralysis, or death even landing in the middle of the bed.
11. Do not allow more than one person on the equipment. Use by more than one person at the same time increase the chance of injury.
12. Use the equipment only with mature, knowledgeable supervision.
13. Bounce in center of the bed. Avoid bouncing when tired.
14. Do not use the equipment while under influence of alcohol or drugs.
15. While keeping the head erect, focus eyes on the equipment toward the perimeter.
16. Stop bounce by flexing knees as feet come in contact with the bed.
17. Before exercising, always do stretching exercises to properly warm up.
18. Maximum user weight is 250 lbs.
19. If the user experience dizziness, nausea, chest pain, or any other abnormal symptoms, STOP the workout at once. CONSULT A PHYSICIAN IMMEDIATELY.

Care and Maintenance

1. For equipment information, contact manufacturer.
2. Periodically inspect all parts for tightness and tighten as required.
3. Replace any worn and damaged part immediately.
4. Use mild household spray cleaners and/or a damp rag to wipe clean. Do not use harsh cleaning chemicals.
5. Sand rusted areas on tubular members and repaint using a non-lead-based paint meeting the requirements of Title 16 CFR Part 1303.
6. Disposal Instructions – The equipment can be safely disassembled and disposed without unreasonable hazards. Call your local recycle agency regarding details of recycling.

Save the Instructions.

WARNING: BEFORE BEGINNING ANY EXERCISE PROGRAM, CONSULT YOUR PHYSICIAN. THIS IS ESPECIALLY IMPORTANT FOR INDIVIDUALS OVER THE AGE OF 35 OR PERSONS WITH PRE-EXISTING HEALTH PROBLEMS. READ ALL INSTRUCTIONS BEFORE USING ANY FITNESS EQUIPMENT. IMPEX INC. ASSUMES NO RESPONSIBILITY FOR PERSONAL INJURY OR PROPERTY DAMAGE SUSTAINED BY OR THROUGH THE USE OF THIS PRODUCT.

SAVE THESE INSTRUCTIONS.

**Impex Fitness Products
2801 S. Towne Ave.
Pomona, CA 91766
200519**

**Phone: 1-800-999-8899
Fax: (626) 961-9966
Email: support@impex-fitness.com**

ASSEMBLY INSTRUCTION

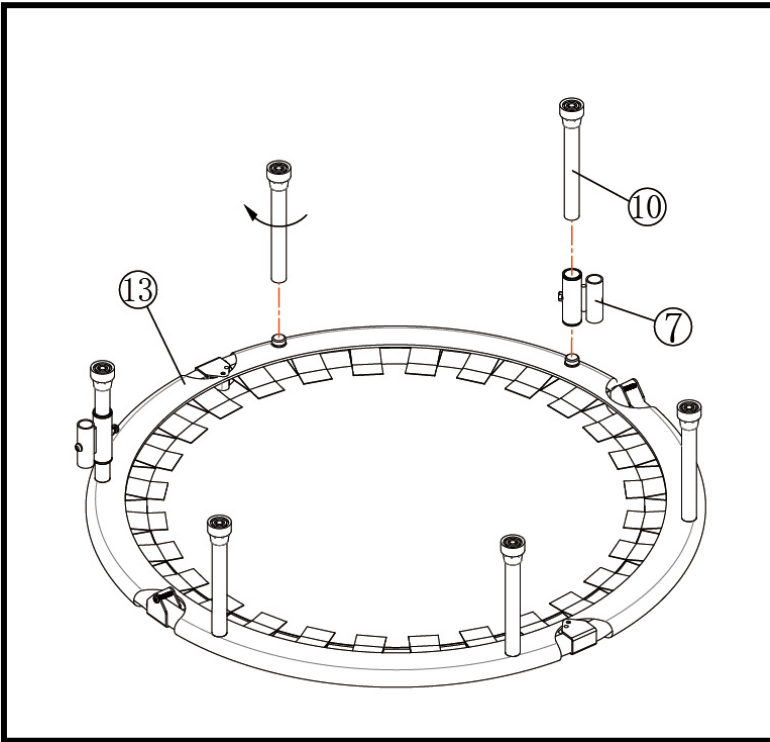

Step-1

- A.) Unfold the Rebounding Bed (#12).
 - B.) Thread six Legs (#10) onto the Rebounding Bed.
 - C.) Slide one Handrail Support (#7) onto one Leg. Skip the next Leg and slide the other Handrail Support onto the 3rd Leg.
- Notice: In case of the squeezing situation,
When opened the trampoline circle,
please spread the rubber belt
equably.

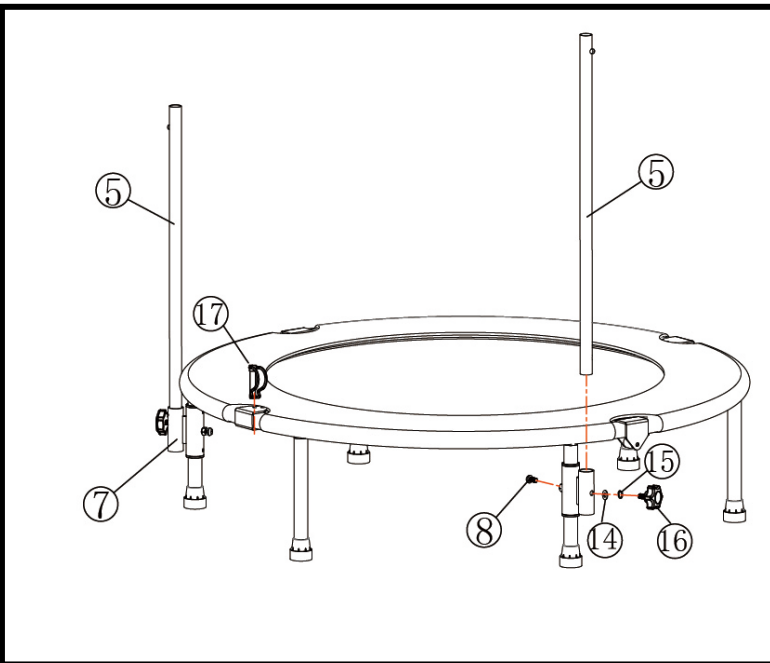

Step 2

- A.) Insert the two Vertical Handrails (#5) into the two Handrail Supports (#7).
- B.) Secure each Vertical Handrail with one M8 x 5/8" Allen Bolts (#8), one Ø5/8" Flat Washer (#14), one 5/8" Spring Washer (#15) and one Lock Knob (#16).
- C.) Insert the lock in (#17) into the hole of Rebounding Bed (#12).

Note: Please insert the safety lock pin (#17) into the hole on the frame before you begin to use the trampoline.
When folding up the trampoline, please remove the lock pin (#17) to fold.

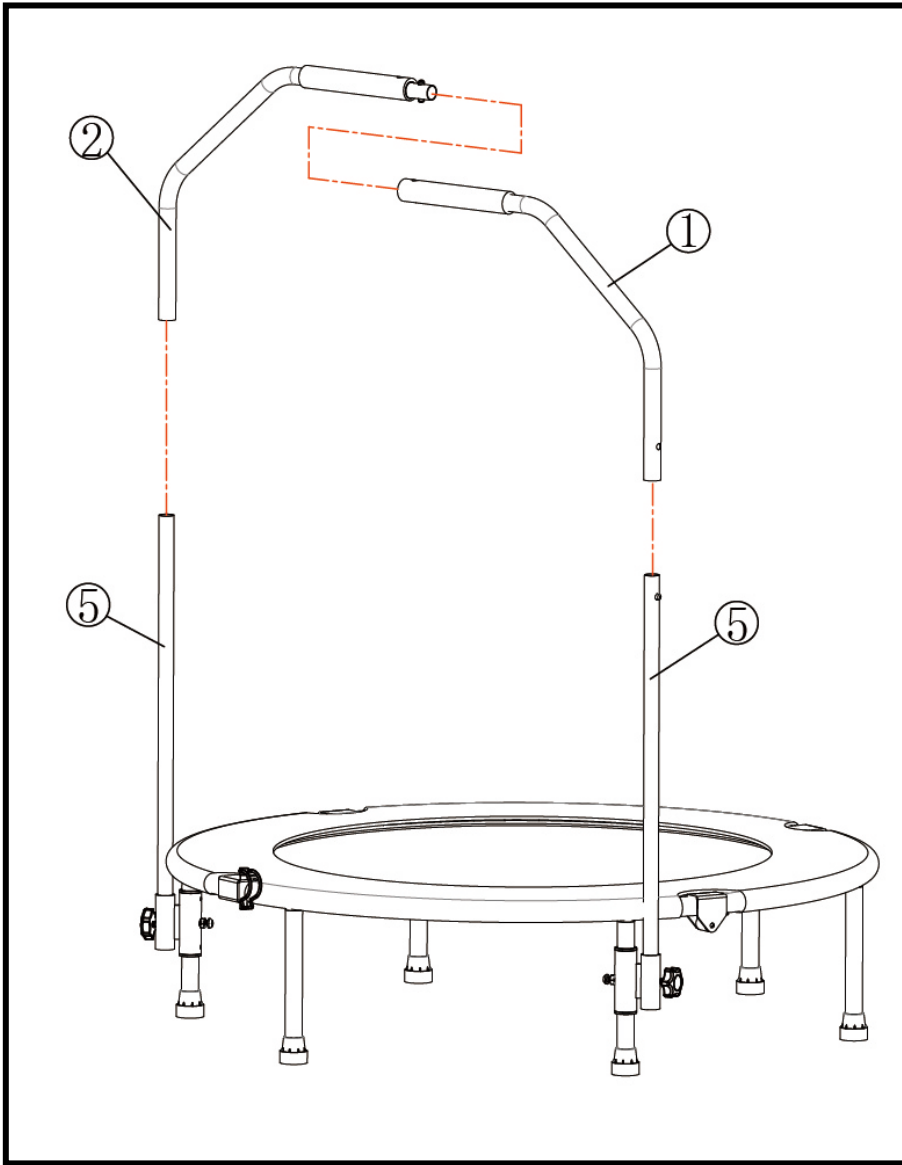

Step 3

- A.) Insert the Right Top Handrail (#2) into Left Top Handrail (#1).
- B.) Insert the Left and Right Top Handrail into the two Vertical Handrails (#5).

EXPLODED DIAGRAM

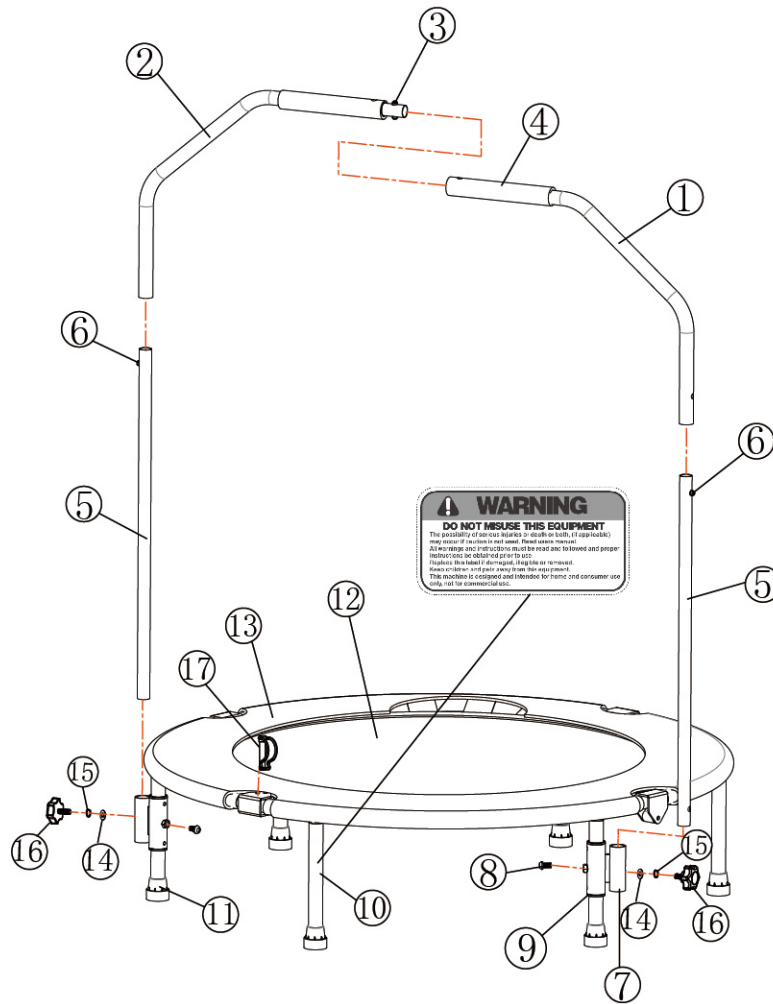

PARTS LIST

Part#	Description	Qty
1	Left Top Handrail	1
2	Right Top Handrail	1
3	Double Clip Spring	1
4	Handle Grip	2
5	Vertical Handrail	2
6	Single Clip Spring	2
7	Handrail Support	2
8	M8 x 5/8" Allen Bolt	4
9	Plastic Bushing	4
10	Leg	6
11	Rubber Base	6
12	Rebounding Bed	1
13	Cover	1
14	Ø5/8" Flat Washer	2
15	Ø5/8" Spring Washer	2
16	M8 Lock Knob	2
17	Lock Pin	1

LIMITED WARRANTY

IMPEX Inc. ("IMPEX[®]") warrants this product to be free from defects in workmanship and material, under normal use and service conditions, for a period of two years on the Frame from the date of purchase. This warranty extends only to the original purchaser. IMPEX's obligation under this Warranty is limited to replacing or repairing, at IMPEX's option.

All returns must be pre-authorized by IMPEX. Pre-authorization may be obtained by calling IMPEX Customer Service Department at 1-800-999-8899. All freights on products returned to IMPEX must be prepaid by the customer.

ORDERING REPLACEMENT PARTS

Replacement parts can be ordered by calling our Customer Service Department toll-free at **1-800-999-8899** during our regular business hours: Monday through Friday, 9 am until 5 pm Pacific standard time.

www.marcypro.com

support@impex-fitness.com

IMPEX[®] INC.

2801 S. Towne Ave, Pomona, CA 91766